

STRENGTH: S. W. L P. L B. L
(Tension) 25Ton 37.5Ton 50Ton
(Shear) 21Ton 31.5Ton 42Ton

FINISH: HOT DIP GALVANIZED.
WEIGHT: 4.5kg

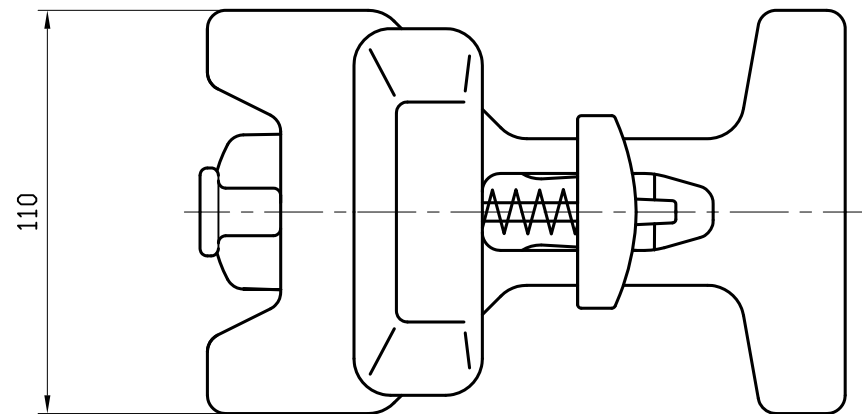

ITEM	NAME OF PARTS	QTY	MATERIALS	WEIGHT (kg)	REMARKS
4	WIRE HANDLE	1	1Cr18Ni9		
3	SPRING	1	1Cr18Ni9/0Cr18Ni9		
2	LOCATED BLOCK	1	ZG40Cr		
1	BODY	1	ZG40Cr		

Description	MIDLOCK				
Date	Drawn by	Checked by	Scale	Edition No.	Page
31/8/2011	Q.N.Zhai	G.H.Yuan	2:1	S	1/1
SCSLASH Locking & Latching Solutions				Slashing Shanghai Co.,Ltd. Tel:86-21-62324652 E-mail:info@sclashing.com	
				Model No.	ML-2